

Effect of Organizational Commitment on Turnover Intention of Senior High Private School Teachers in Cebu City, Philippines

Ma. Vanesa Oberes¹

mvfoberes@usc.edu.ph
University of San Carlos

Tiffany Adelaine Tan²

tgatan@up.edu.ph
University of the Philippines Cebu

Abstract The additional two years of the country's basic education program worsened the private school teacher shortages, posing a potential problem to retain competent teachers as they are affected by teachers' migration to public schools. This paper examined the effect of organizational commitment on turnover intention of senior high (S.H.) private school teachers in one of the biggest cities in the country. Purposive sampling was used to collect data from the top four S.H. private schools in Cebu City with the highest number of students. A total of 220 Cebu City-based teachers completed the survey. Confirmatory factor analysis was used to analyze the collected data. Results show that affective and normative commitments have significant and negative relationships with turnover intention. These results suggest that private schools in Cebu City need to develop activities that can build teacher-institution relationships to increase the emotional attachment and obligations of the teachers to stay for their students and institution. The study recommends to conduct a study exploring mediating factors (e.g., job satisfaction and employee empowerment) to provide more comprehensive results on turnover intention.

Keywords: *Educational administration; educational quality; teacher's commitment; teaching profession; turnover intention*

Introduction

It is common knowledge that education is key to a country's development and can even contribute to national identity (Idris et al., 2012). Unfortunately, it is also believed that the quality of education is adversely affected by teacher turnover (Hanushek et al., 2016) and teacher shortage (Wiggan et al., 2021). For instance, one factor that drives the emerging teacher shortage in the U.S. is high teacher attrition (Sutcher et al., 2016). It was estimated that by 2024, the projected shortage of new hires would be over a hundred thousand (García & Weiss, 2019). This trend is not exclusive to the U.S. alone. In a report by the United Nations (United Nations Educational Scientific and Cultural Organization [UNESCO], 2016), the number of teachers needed globally for secondary education alone is 19 million by 2025 and 27 million by 2030 to achieve the U.N.'s Sustainable Development Goal (SDG 4), ensuring quality education for all. Thus, for educational institutions to fulfill SDG 4, school administrators must recruit and attract qualified teachers to stay in the profession.

While the teaching profession is complex and demanding, teacher commitment is critical to the success of educational reforms, school's achievement of one's vision and goals (Selemat, 2013), student preparation for tertiary education, development of middle-level skills, entrepreneurship, and global employment (Arcangel, 2014). Organizational commitment has long been of interest to academics and practitioners because of its influence on retention or teachers' turnover intentions (Jonathan et al., 2013; McInerney et al., 2015). Thus, it is inevitable for schools to

enhance teacher commitment to influence turnover intention positively and successfully deliver educational reforms.

The Philippines established the Enhanced Basic Education Act of 2013 to align its educational system to the world. The Act, known as the K to 12 program, enhances the Philippine basic education by adding two years for Senior High School (SHS), having been the last country in Asia and one of the last three countries in the world that still had the 10-year basic education program. This reform is a big leap for the country to be at par with global standards. Moreover, this is the country's competitive move to equip learners with appropriate skills, creativity, and intelligence (Bermudez, 2018).

In the first year of the K to 12 program, SHS enrollment reached over a million. The new program resulted in shortages of teachers and lack of school facilities nationwide as the number of enrollees continued to increase (Bosano et al., 2019). Around 30 percent of the enrollment went to private schools (Geronimo, 2016) due to the perceived gap in the students' achievement and performance between public and private schools (Bernardo et al., 2015). Furthermore, the implementation of the government's SHS voucher program provides financial aid to eligible students enrolling in private schools (Department of Education, 2017). The program aims to increase access and diversity to SHS providers and offer more program choices that will suit the needs and career goals of the student, contributing to the enrolment among private schools. Engaging the private sector has reduced the government's institutional pressures in implementing the law, especially on the need for infrastructure, decreasing the public school congestion, and improving the learning environment. (Department of Education, 2015).

Teacher turnover in the Philippines at the basic education level (i.e. in private schools) is due to low salary,

heavy workload, long work hours, lack of challenge, and personal circumstances that force them to search for better opportunities (Braid, 2015). To compound this issue, private school teachers migrate to public schools because of the higher salaries and better benefits offered to them; thus, creating a problem for private schools in retaining teachers (Hernando-Malipot, 2018). Turnover of teachers is a concern because schools take a financial toll when replacing teachers and in dealing with teacher shortages through hiring unqualified teachers, cutting of class offering, and increasing class size which negatively impact the quality of instruction and student learning (Sutcher et al., 2019).

After a thorough search online, the proponents observed limited studies on young Filipino teachers' commitment to their profession. The lack of attention is unfortunate for three reasons. First, the high turnover rate is costly and adversely affects a school's overall performance. Secondly, a considerable percentage (27.3%) of the Filipino workforce is between 24 to 35 years old (Philippine Statistics Authority, 2020). Lastly, understanding teachers' commitment will help school administrators develop programs to keep excellent young teachers in their institutions.

Thus, this current study determined the extent of the S.H. private school teachers' organizational commitment to their turnover behavior. Two objectives were set to respond to the aforementioned aim:

- (1) Determine the level of organizational commitment of S.H. private schools' teachers; and
- (2) Examine the effect of teachers' affective, continuance, and normative commitment on their turnover intention.

Organizational Commitment

Fellows and Kessler (2016) defined organizational commitment as one's strong level of attachment and loyalty, desire to maintain connectedness with the organization and willingness to exert effort on behalf of the organization. They further noted that commitment exists when one's goals are congruent with those of the organization, implying continued employment. As a result, a committed teacher will exhibit a strong sense of professionalism in what they do and prioritizes the students' best interests when it comes to learning and well-being (Fransson & Frelin, 2016).

Components of Organizational Commitment. Allen and Meyer (1990) pointed out that attitudinal organizational commitment comprises three components:

- (1) Affective commitment refers to the degree of an employee's feeling of emotional attachment, involvement, and identification with their organization.
- (2) Continuance commitment refers to an awareness of the cost and difficulty associated with leaving the organization.
- (3) Normative commitment refers to a feeling of obligation to continue employment because it is the "right and moral" thing to do.

The findings of previous studies offered different results. For instance, BinBakr and Ahmed (2015) proposed that faculty members highly demonstrate affective commitment, while the results of Çağla Garipağaoğlu (2013) noted that teachers scored lowest on the normative commitment and highest on the continuance commitment of private school teachers in Turkey. Furthermore, Khan (2015) found that private school teachers' overall commitment is

higher than public school teachers. The study pivots on the lack of job security in private schools, causing the disparity in organizational commitment (Khan, 2015).

Turnover Intention

Turnover intention is the extent of the employees leaving their organizations. It is the conscious will to look for a job outside the organization (Tett & Meyer, 1993). Teacher turnover is a significant concern in education because of its impact on student learning outcomes; thus, reducing the quality of education (Grant et al., 2019). In the Philippines, the turnover intention is higher among private-sector employees due to lack of security and tenure compared to public sector employees. Furthermore, turnover among teachers is more likely to quit school than abandoning the teaching profession (Liu & Onwuegbuzie, 2012; McInerney et al., 2015).

A strong negative relationship with turnover intention has been shown with pay (Shah & Jumani, 2015) and intrinsic motivation (Grant et al., 2019) among secondary and early childhood education teachers. Organizational commitment is the most potent contributor to turnover prediction in several studies. Studies after studies suggest that organizational commitment has a significant negative relationship with turnover intention (Gatling et al., 2016; Jonathan et al., 2013).

Organizational Commitment and Intention to Leave

Several studies argued that all three commitment components negatively and significantly reduce turnover intentions (Imran et al., 2017). As to the extent of the influence of each dimension, Gatling et al. (2016) noted that affective commitment is the most significant negative predictor of intention to leave in their study on the effects of authentic leadership and organizational commitment on turnover

intention. McInerney et al. (2015) further suggested that teachers' affective commitment to their profession and organization is an important negative predictor of turnover intentions among teachers. However, in the same study, they also proposed that normative commitment is a strong negative predictor of intention to leave current school and profession. On the other hand, continuance commitment also negatively correlates to turnover intention (Klein & Park, 2015).

Jonathan et al. (2013) also examined the factors contributing to teachers' intention to leave. Their results showed that teachers with high intention to leave had a low affective commitment, moderate continuance commitment, and very low normative commitment. Affective and continuance commitment provided a substantial and unique contribution to teachers' intention to leave. Continuance commitment showed a stronger predictor of intent to leave among secondary school teachers. On the other hand, normative commitment did not show a unique contribution.

Therefore, the following are what the study hypothesizes, as shown in Figure 1:

H₁: The affective commitment of S.H. private school teachers negatively affect turnover intention.

H₂: The continuance commitment of S.H. private school teachers negatively affect turnover intention.

H₃: The normative commitment of S.H. private school teachers negatively affect turnover intention.

The hypothesized model (Figure 1) shows the latent variables in ellipses, which are the three organizational commitment components and the turnover intention. The

Figure 1

Hypothesized Model

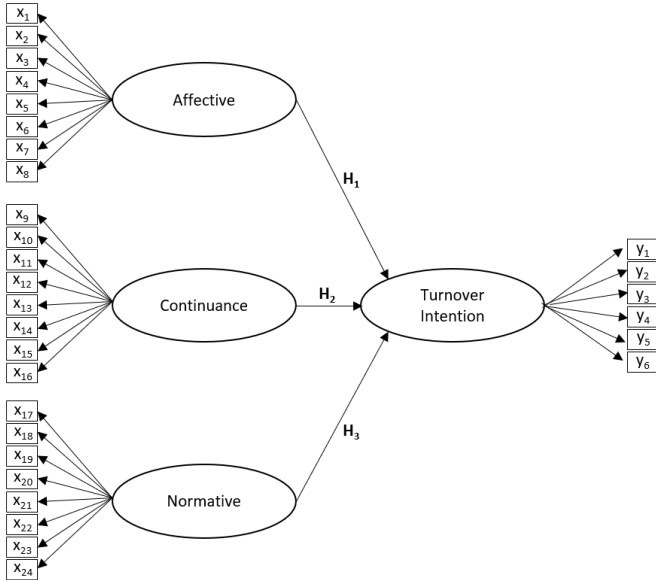

latent variables are measured by the items in rectangular nodes from the studies of Allen and Meyer (1990), and Roodt (2004), respectively. Each of the commitment components has eight observed variables and six for the turnover intention. The model hypothesizes that each commitment component negatively affects turnover intention.

Methodology

Research Design

A quantitative causal research design was used to determine the extent of the relationship between two variables, namely organizational commitment and turnover intention using statistical data. This research design was chosen since the study aims to measure the causal effect of the independent

variable (organizational commitment) to the dependent variable (turnover intention). Moreover, empirical data through a structured survey shall recognize trends and patterns among SHS teachers to test the hypotheses presented.

Participants

When the K to 12 program was implemented, SHS enrollment reached over a million, where around 30 percent went to private schools (Geronimo, 2016). In the Philippines, Region VII recorded the highest net enrollment rate for elementary at 98.41%. While the region posted 78.51% for secondary level for school year 2017 – 2018, higher than the national average of 76% (Philippine Statistics Authority, 2019). Cebu City, the region's center, is the core of education in the Visayas and is one of the most developed provinces in the Philippines. Furthermore, out of the 355 schools offering SHS in Region VII, 75% are in Cebu.

Purposive sampling was used to collect data. The top four SHS private schools in Cebu City with the highest number of students were chosen for this current study. In 2018, the total enrollment of SHS students in private schools was 27,042, of which 13,000 students (48 percent) were enrolled in these four selected schools. Using the national standard for teacher-student ratio of 1:40 (Montemayor, 2018), there are about 676 (27,042 students divided by 40) teachers in reference to this ratio. For this current study, 220 respondents correspond to 32.5 percent of the estimated number of S.H. teachers in Cebu City.

Instruments

This study adopted the Organizational Commitment Questionnaire (OCQ) developed by Allen and Meyer (1990) to determine dimensional commitment. There are

eight questions for each of the three components. As of this writing, their article has been cited by at least 19,700 authors in Google Scholar (BinBakr & Ahmed, 2015; Maqsood et al., 2015). The results of Maqsood et al. (2012) revealed that OCQ performs better within a group of teachers, thus demonstrating support to the existing three-factor structure of organizational commitment. As for the reliability of the instrument, Cronbach's alpha of several studies ranged from .77 to .85 for affective commitment, .70 to .77 for normative commitment, .75 to .83 for continuance commitment, and .85 to .89 for the overall questionnaire (BinBakr & Ahmed, 2015; Jonathan et al., 2013; McInerney et al., 2015). Independent variables, "x1" to "x24," are assigned to each item for the data analysis. A 5-point Likert-type scale (1- strongly disagree to 5- strongly agree) was used to measure organizational commitment.

For the dependent variables, the questionnaire developed by Roodt (2004) was used. Several studies have used the Turnover Intention Scale (TIS-6) and recorded a good Cronbach's alpha ranging from .80 to .86 (Christopher et al., 2018; Mashile et al., 2019). TIS-6 has established its reliability ($\alpha = .80$) and criterion-predictive and differential validity (Bothma & Roodt, 2013). Similarly, 5-point Likert-type scales (1-Never to 5-Always) were used to measure turnover intention. Variables "y1" to "y6" are assigned to each item for the data analysis.

Data Collection

Invitation letters were sent to the principals of the four private schools, explaining the rationale of the research and asking permission to administer the survey to their teachers. One of the proponents visited the institutions to secure approval. The data-gathering proved challenging due to the different university procedures and teachers' schedules. Most of the schools visited were willing to participate in the

study; however, since their teachers were busy and schedules were full, the principal preferred to distribute the survey themselves to teachers who were only willing to answer the questionnaire in their free time. Thus, one of the proponents left copies of the research information, consent form and survey questionnaire, equivalent to the number of faculty for each school and retrieved them after a week. Forty to seventy percent of the surveys were returned with complete answers. For the rest of the schools, the principals suggested that the proponent be the one to conduct the survey at the different branches and was given a time during their faculty gathering. The study was discussed prior to the distribution of the tool and was retrieved back as soon as the respondent finished responding to the instruments.

In a span of two months, the proponents were able to gather 220 completed questionnaires from the top four S.H. private schools in Cebu City. The acceptable number of respondents for CFA's output to be unbiased must be at least five respondents to one item (Bentler & Chou, 1987). Since there are 30 questions in this survey, the minimum number of completed questionnaires should be at least 150, which is also an acceptable parameter for measuring less than seven constructs and modest communalities (Hair et al., 2014). Thus, the gathered data for this study is more than the acceptable parameter.

Data Analysis

Descriptive statistics such as mean and standard deviation were generated to describe the data set and present the relationships between the hypothesized variables. In addition, confirmatory factor analysis (CFA) was the statistical technique used to test hypothesized relationships. Root Mean Square Error of Approximation (RMSEA), Chi-square/degrees of freedom (CMIN/DF), and Comparative Fit Index (CFI) were computed to determine the fit of the model. RMSEA values

should range from .03 to .08, CMIN/DF should be less than 3.0, with $p\text{-close} > .05$ (Hair et al., 2014), and CFI should be at least .85 (Harlow et al., 2016) for an acceptable goodness-of-fit statistics. Since the research model presents multiple constructs, the convergent validity of the scale was tested by analyzing the t-values and size of the factor loading of at least .5 (Hair et al., 2014). To check for discriminant validity, the fit indices of a one-dimension model were compared to the proposed three-dimension commitment model. Finally, Cronbach's alpha was conducted to test the reliability of the instrument and estimate the responses' internal consistency.

Ethical Considerations

To fulfill the ethical requirements, transmittal letters were sent to the principals of the chosen high schools. The invitation letter included the researchers' names, affiliation, and purpose of the study. The letter also assured the school heads that participation in the study is purely voluntary and there are no adverse consequences if the school or the teachers decide not to participate. Once the request letter was approved, the questionnaires were handed to the school's supervisors or assigned personnel. Every participant had to sign the informed consent, a document that discusses the purpose, study procedures, risks, benefits, confidentiality clause, and the contact details of the researchers. To signify their understanding and interest in joining the research, they had to sign the Research Information Sheet and Consent Form before the respondents could proceed to accomplishing the survey.

Results and Discussion

Table 1 presents the demographic profile of the respondents. Out of the 220 respondents, 58 percent are female, roughly three-fourths are single, and half are less than 27 years old.

Table 1

Respondents' Descriptive Statistics, n=220

Gender	# (%)	Age (years)	# (%)	Years in the institution	# (%)
Male	92 (42%)	<27	110 (50%)	0-3	155 (70%)
Female	128 (58%)	27-35	58 (26%)	4-10	43 (20%)
		36-45	35 (16%)	11-19	14 (6%)
		>45	17 (8%)	>19	8 (4%)
Marital Status		Eligibility		Employment Status	
Single	163 (74%)	Licensed Teacher	153 (70%)	Full-time permanent	40 (18%)
Married	55 (25%)	Non-Licensed	67 (30%)	Full-time probationary	175 (80%)
Widow/ Separate	2 (1%)			Part-time	5 (2%)
Educational Attainment		Years working in the profession			
Bachelor's	155 (70%)	0-3	113 (51%)		
Masters	58 (26%)	4-10	66 (30%)		
Doctorate	7 (3%)	11-19	29 (13%)		
		> 19	12 (5%)		

Only 30 percent of the respondents have a postgraduate degree, while 70 percent teach with a professional teacher license. Table 1 also shows that most respondents are relatively new in the profession. Regarding employment status and experience, 70 percent have been employed in their current institutions for less than three years. Furthermore, 80 percent are full-time teachers on probationary status. Overall, half of the respondents are new teachers with less than three years working in the profession, and another 30 percent with four to ten years of teaching experience.

Table 2 shows the mean and standard deviation of the three organizational commitment components and turnover intention. On average, respondents indicated agreement with their affective commitment (M=3.7, SD=0.94) while undecided with their continuance (M=3.3, SD=1.10) and normative (M=3.3, SD=1.02) commitments. The average also shows lower turnover intention (M=2.69, SD=1.01). Furthermore, the teacher's turnover intention average score is 16.18 (sum of the six items), which is less than 18, indicating a desire to stay (Roodt, 2004; Turney, 2021).

Table 2

Descriptive statistics of the Commitment Components and Turnover Intention

Organizational Variable	Score	
	M (Mean)	SD (Standard Deviation)
Affective Commitment	3.7	0.94
Continuance Commitment	3.3	1.10
Normative Commitment	3.3	1.02
Turnover Intention	2.69	1.01

Table 3 shows that the fit indices of the proposed model before any modification were poor. Bentler and Chou (1987) proposed releasing or dropping some constraints to improve the model fit. Thus, items with very low factor loadings (below .3) were removed to improve the model fit. For instance, five reverse questions, *x4*, *x12*, *x19*, *x24*, and *y2*, were removed, which might have confused the respondents as they were answering. Two items were also removed due to low factor loadings, *x3* and *x17*, which pertain to teachers' experiences and the meaning of the profession. Since 70 percent of the respondents are relatively new to the profession, these statements may not have been

relevant to them at this time. Even if the four items from the commitment dimensions and three items from the turnover intention were marginally below .50, the loadings for these items are statistically significant at $p < .001$ and, thus, could be accepted (Obal et al., 2015). After removing these items, the fit indices improved (Table 3), as shown in Figure 2. To further improve the CFI, the residual covariance matrix was assessed and looked for items that showed high covariances (greater than the value of absolute 2). As a result, *x13* was removed (covariance > 4.55). Figure 3 shows the final model and good fit indices (Table 3).

Table 3

Fit Indices Comparison of the Different Models

	CMIN/DF	CFI	RMSEA	<i>p</i>-close	Remarks on the fit
Original 3-factor model	2.431	0.667	0.081	0.000	Poor fit
Modified 3-factor model (Figure 2)	1.677	0.898	0.056	0.176	Acceptable fit
Modified 3-factor model (Figure 3)	1.485	0.929	0.047	0.656	Good fit
One factor model	3.270	0.465	0.102	0.000	Terrible fit

The organizational commitment items were assigned to one factor to test for discriminant validity, and Table 3 shows that the one-factor model has a terrible fit. Comparing these fit indices with the three-factor model proposed suggests that the two models are different.

In Table 4, the critical ratios of the different measures suggest that values higher than 1.96 for a regression weight are significant at $p < .001$. The Cronbach's alpha value for commitment components ranges from .658 to .758,

Table 4.

CFA results of the Organizational Commitment Components and Turnover Intention

Measurement	Standard Coefficient	Critical Ratio/ t-value	Cronbach's alpha based on standardized items	Average Extracted Variance (AVE) ^b
x8<-- Affective	.843	7.136 ^a	.755	.612
x7<-- Affective	.256	5.825 ^a		
x6<-- Affective	.765	10.311 ^a		
x5<-- Affective	.811	11.511 ^a		
x2<-- Affective	.237	5.567 ^a		
x1<-- Affective	1.263	7.136 ^a		
x16<-- Continuance	.781	4.307 ^a	.758	.358
x15<-- Continuance	.638	8.853 ^a		
x14<-- Continuance	.427	7.090 ^a		
x11<-- Continuance	.616	7.883 ^a		
x10<-- Continuance	.540	6.569 ^a		
x9<-- Continuance	.383	4.307 ^a		
x23<-- Normative	.445	3.830 ^a	.658	.305
x22<-- Normative	.644	4.361 ^a		
x21<-- Normative	.514	4.077 ^a		
x20<-- Normative	.725	4.471 ^a		
x18<-- Normative	.352	3.830 ^a		
y1<-- Turnover Intention	.824	5.498 ^a	.709	.373
y3<-- Turnover Intention	.482	6.895 ^a		
y4<-- Turnover Intention	.769	10.301 ^a		
y5<-- Turnover Intention	.448	6.374 ^a		
y6<-- Turnover Intention	.403	5.498 ^a		

^at-values significant at p<.001

^bAVE=average of the squared multiple correlations of all items belonging to a particular latent variable

Figure 2

Estimates of Organizational Commitment Components and Turnover Intention (with modification).

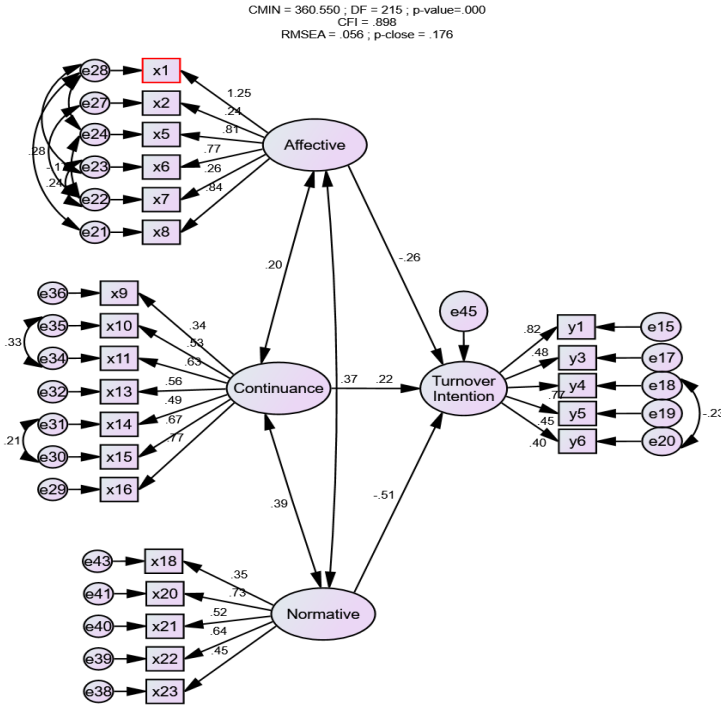

which is considered acceptable or adequate (Vaske et al., 2017). Overall, the Cronbach's alpha of the organizational commitment questionnaire is .793. To test for convergent validity, the average extracted variance (AVE) was also computed. Though the AVE computed is below .5 except for Affective, the composite reliability (Cronbach's alpha) is higher than .6; therefore, the convergent validity of the construct is still adequate (Fornell & Larcker, 1981).

Table 5 shows that not all path coefficients support the hypothesized model revealing that affective and normative components of organizational commitment have a significant and negative relationship to the turnover intention

Figure 3

Estimates of Organizational Commitment Components and Turnover Intention (trimmed and modified)

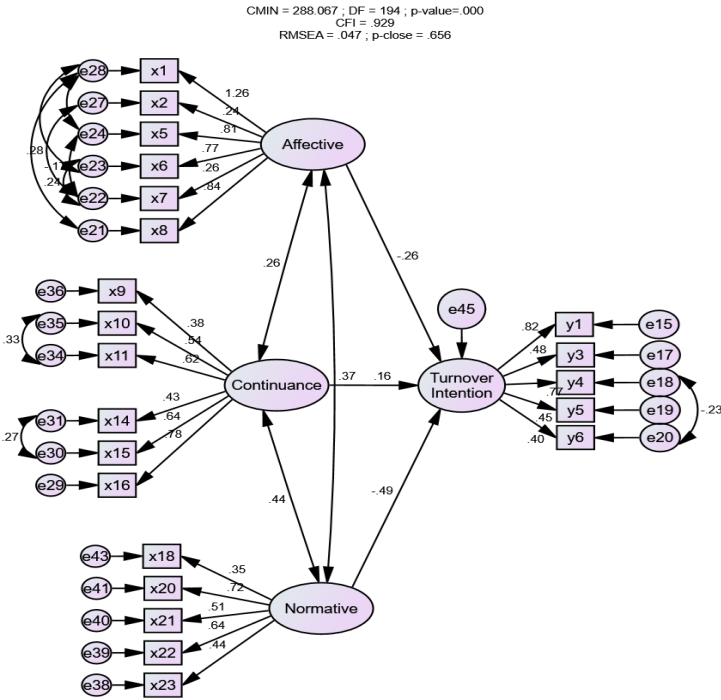

Table 5

Standard Coefficient Estimates.

Measurement	Standard Coefficient	Critical Ratio (C.R.)/ t-value
Turnover Intention <--- Affective	-0.258	-4.191 ^b
Turnover Intention <--- Continuance	0.161	1.777 ^a
Turnover Intention <--- Normative	-0.495	-3.469 ^b

^at values significant at p<0.10

^bt values significant at p<0.001

with coefficients of $-.258$ and $-.495$, respectively supporting Hypotheses 1 and 3. On the other hand, continuance commitment showed a positive (0.161) but non-significant relationship ($p = .076$) to turnover intention, which does not support Hypothesis 2.

The negative and significant relationship with turnover intention ($p < .001$) indicates that if affective and normative commitments increase, the teacher's intention to leave will be lower. The results for hypotheses 1 and 3 are consistent with previous research (McInerney et al., 2015; Shah & Jumani, 2015; Imran et al., 2017). The various studies mentioned also revealed a negative relationship of continuance commitment to turnover intention. However, this current study resulted otherwise as hypothesized. The results show that continuance commitment has a positive and non-significant relationship ($p = .076$) with the teacher's intention to leave, implying that as continuance commitment increases, there is a higher likelihood that the teachers will leave. A possible explanation for this inconsistency could be that since the K to 12 programs added two more years in high school, this created a demand for SHS teachers. Since the demand for teachers is higher than the supply (David et al., 2019), teachers are not concerned about not finding another job at the moment with several alternatives available. García and Weiss (2019) also ascertained that if qualifications and credentials are considered then teacher shortage is higher than what it is today. This result further implies that teachers are not concerned about not finding a teaching job aside from their current employment.

Secondly, many private schools receive lower salaries than public school teachers. Teachers perceive that teachers in private schools are suffering from unequal treatment with their salaries and benefits, particularly those in basic education and schools outside the National Capital Region (Quismorio, 2019). Since 80 percent of the respondents of

this research are still on probationary status, it is unlikely that they had formed a strong bond with their organizations at this moment. In the Philippines, teachers need to complete a three-year probationary period before attaining permanency in a private educational institution. Furthermore, 50 percent of the respondents are young teachers who are still gaining experience from their institutions. Allen and Meyer (1990) pointed out that continuance commitment develops when an employee has invested a magnitude of time and energy in mastering their job skills in their organization. Though weak and non-significant, the positive relationship of continuance commitment to turnover intention can still threaten private schools in the successful implementation of SHS. The positive relationship between continuance commitment and turnover intention implies that the young teachers in the study may be using their current employment to gain teaching experience only and not necessarily tenure. Such that once a better opportunity presents itself, they would easily transfer employment. This result concurs with the study of Sow, 2015 among employees which also did not cover demographic factors such as age that could affect the relationship. Thus, factoring in the teacher migration to public schools due to differences in salary, benefits, and job security, retaining competent teachers in S.H. private schools to deliver quality and improve learning outcomes in SHS implementation (Hernando-Malipot, 2018) becomes questionable.

The moderate to weak coefficients for the affective and normative dimensions suggest that teachers in this current study have not yet actively developed the three dimensions of organizational commitment. Jonathan et al. (2013) offer support, noting that normative and continuance commitment increases as age increases. Furthermore, tenured teachers relatively display a higher level of commitment to protecting the due promotions and benefits that may be associated with

tenure. Thus, the moderate to weak coefficient results may be due to the respondents' age and non-tenured status.

Lastly, the average score of the teachers' turnover intention indicates a desire to stay in the organization. The rating suggests that when the respondents are more exposed to an environment developing affective and normative commitments, they would likely remain in the organization. However, financial incentives are a great deal to employees.

Conclusion and Recommendations

This paper examines the relationship between the components of organizational commitment: affective, continuance, normative, and turnover intention of SHS private school teachers in Cebu City. The results show moderate support for Hypothesis 1 and 3, while no support for Hypothesis 2. The results indicate that affective commitment (desire or feeling of attachment) and normative commitment (sense of obligation) negatively impact teachers' intentions to leave the organization. An influential teacher's involvement, growing emotional attachment, identification of the organization's goals and values, and the organizations' investment in money or time for training and trusting the teachers with responsibilities can significantly affect their intention to stay in their organization. However, continuance commitment (needs or cost of leaving) may influence the teacher to leave the organization due to the current demand for SHS teachers for private and public schools. Thus, to retain skilled and competent teachers, S.H. private schools need to develop their teachers' affective and normative commitment. For instance, private schools may exempt qualified and excellent teachers from the three-year probation rule. In addition, offering permanency early in the career of quality teachers (e.g., excellent student evaluation of teaching, likely to pursue

Ph.D., and do research) will give the educational institution the leverage of retaining them.

Another way to increase the affective and normative commitments is to carve out a career development plan for excellent young teachers. For instance, support them by allowing them to attend conventions to build up their leadership skills, values, teaching, and research skills. Couple the career development plan with a lineup of training courses and workshops that support the teachers' career path with the school. In doing so, teachers may perceive that the school administration cares about their needs, hears, and values them. Such efforts may further increase the teachers' positive emotion, obligation to continue employment. It will not also hurt private schools to review their remuneration package and offer a more comparable compensation package with public schools. This study supports lawmakers' call to DepEd to provide financial incentives to private school teachers. Though money may result in superficial relationships (Fenton-O'Creevy & Furnham, 2020), it may increase teachers' positive emotions, obligations, and the cost of leaving the school. DepEd should not take this concern of the private schools lightly as they have helped reduce the government's institutional pressures in implementing the law, especially on the need for infrastructure to cater to additional grade levels (Department of Education, 2015).

Finally, private schools may also include questions about the values and priorities of the teachers when they apply to their schools. For example, a recent study by Khairunnisa et al. (2021) suggested that organizational culture negatively affects employee turnover behavior. Thus, private schools may choose applicants whose values and priorities align with theirs, not just evaluate them based on teaching experience.

Limitations

One limitation of the study is the low turnout of respondents. Though the minimum number was sufficiently met, the results would better represent SHS teachers' commitment level and intention to stay in the organization if more teachers of all ages joined the study to lessen the demographic impact. Secondly, this study only examined the direct effect of commitment on turnover intention. Thus, future research could include mediating factors, such as job satisfaction and employee empowerment, on turnover intention. Lastly, this study did not consider the qualitative reasons for teachers' intention to leave. Thus, it would be beneficial to know the reasons for teachers leaving their organization for future research. For instance, if the teacher intends to leave the educational institution, will she continue to teach in the Philippines (transfer to a public or another private school), teach in a foreign country, or move to another industry, which can help establish associations with the three commitment components.



References

- Allen, N. J., & Meyer, J. P. (1990). The measurement and antecedents of affective, continuance and normative commitment to the organization. *Journal of Occupational Psychology*, 63(1), 1-18. <https://doi.org/10.1111/j.2044-8325.1990.tb00506.x>
- Arcangel, X. (2014, June 30). DepEd to need 81k teachers for senior high school by 2016. *GMA News*. <https://www.gmanetwork.com/news/news/nation/367987/dep-ed-to-need-81k-teachers-for-senior-high-school-by-2016/story/>

- Bentler, P. M., & Chou, C. P. (1987). Practical issues in structural modeling. *Sociological Methods & Research*, 16(1), 78-117. <https://doi.org/10.1177/0049124187016001004>
- Bermudez, M. (2018, April 07). *What went before: The K-12 program*. Inquirer.net. <https://newsinfo.inquirer.net/980733/what-went-before-the-k-12-program>
- Bernardo, A. B., Ganotice, F. A., & King, R. B. (2015). Motivation gap and achievement gap between public and private high schools in the Philippines. *The Asia-Pacific Education Researcher*, 24(4), 657-66. <https://doi.org/10.1007/s40299-014-0213-2>
- BinBakr, M. B., & Ahmed, E. I. (2015). An empirical investigation of faculty members' organizational commitment in the Kingdom of Saudi Arabia. *An Empirical Investigation of Faculty Members' Organizational Commitment in the Kingdom of Saudi Arabia*, 3, 1020-1026. <https://doi.org/10.12691/education-3-8-12>
- Bosano, R., Aguilar, J., Canoy, J., Vicencio, L., Rutao, G., & Cariño, J. (2019, June 03). *27 Million return to school as classroom, teacher lack persists*. ABS-CBN News. <https://news.abs-cbn.com/news/06/03/19/27-million-return-to-school-as-classroom-teacher-lack-persists>
- Bothma, C.F.C., & Roodt, G. (2013). The validation of the turnover intention scale. *SA Journal of Human Resource Management/SA Tydskrif vir Menslikehulp-bronbestuur*, 11(1), Art. #507, 12 pages. <https://journals.co.za/doi/abs/10.4102/sajhrm.v11i1.507>
- Braid, F. (2015, October 21). *Teachers and our state of education*. Manila Bulletin. <https://www.pids.gov.ph/pids-in-the-news/1359>
- Çağla Garipağaoğlu, B. (2013). Examining organizational commitment of private school teachers. *Journal of Educational & Instructional Studies in the World*,

3(2). <https://web.s.ebscohost.com/abstract?direct=true&profile=ehost&scope=site&authtype=crawler&jrnI=21467463&AN=90547125&h=KiQxOblu4dSWG Oi4qNfa7pcgJU9PPEBMr6Tgz7X67xWOEwOBVK iS44IqJuv9aFaQw2pNj5uAbepMtAmsw6kWzw%3d%3d&crl=c&resultNs=AdminWebAuth&resultLoca l=ErrCrlNotAuth&crlhashurl=login.aspx%3fdirect% 3dtrue%26profile%3dehost%26scope%3dsite%26a uthtype%3dcrawler%26jrnl%3d21467463%26AN% 3d90547125>

Christopher, S. A., Fethney, J., Chiarella, M., & Waters, D. (2018). Factors influencing turnover in GenX nurses: Results of an Australian survey. *Collegian*, 25(2), 217-225. <https://doi.org/10.1016/j.colegn.2017.06.003>

David, C., Ducanes G., Yee, K.M., & Generalao I.N. (2019). *Teacher Education in the Philippines: Are we meeting the demand for quantity and quality?*. <https://peac.org.ph/wp-content/uploads/2019/12/5-Dr.-Clarissa-David-Harmonizing-Teacher-Supply-and-Demand.pdf>

Department of Education. (2015). *Policy guidelines on the implementation of the senior high school (SHS) voucher program and under the government assistance to students and teachers in private education (GASTPE)*. <https://peac.org.ph/wp-content/uploads/2017/09/DepEd-Order-No.-11-s.-2015-.pdf>

Department of Education. (2017). *Guidelines on the implementation of the senior high school (SHS) voucher program effective school year 2017-2018*. https://www.deped.gov.ph/wp-content/uploads/2017/04/DO_s2017_019.pdf

Fenton-O'Creevy, M., & Furnham, A. (2020). Money attitudes, personality, and chronic impulse buying. *Applied Psychology*, 69(4), 1557-1572. <https://doi.org/10.1111/apps.12215>

- Fellows, S., Kahn, W. A., & Kessler, E. H. (2016). Encyclopedia of management theory. https://www.researchgate.net/publication/264205545_Organizational_commitment_theory
- Fornell, C., & Larcker, D. F. (1981). Evaluating structural equation models with unobservable variables and measurement error. *Journal of Marketing Research*, 18(1), 39-50. <https://doi.org/10.1177/002224378101800104>
- Fransson, G., & Frelin, A. (2016). Highly committed teachers: What makes them tick? A study of sustained commitment. *Teachers and Teaching*, 22(8), 896-912. <https://doi.org/10.1080/13540602.2016.1201469>
- García, E., & Weiss, E. (2019). The teacher shortage is real, large and growing, and worse than we thought. The first report in «The Perfect Storm in the Teacher Labor Market» Series. *Economic Policy Institute*. <https://eric.ed.gov/?id=ED598211>
- Gatling, A., Kang, H. J. A., & Kim, J. S. (2016). The effects of authentic leadership and organizational commitment on turnover intention. *Leadership & Organization Development Journal*, 37(2), 181-199. <https://doi.org/10.1108/LODJ-05-2014-0090>
- Geronimo, J. (2016, June 17). *DepEd: Senior high school enrollment hits 1 million*. Rappler. <https://www.rappler.com/nation/136758-senior-high-school-enrollment-one-million>
- Grant, A. A., Jeon, L., & Buettner, C. K. (2019). Relating early childhood teachers' working conditions and well-being to their turnover intentions. *Educational Psychology*, 39(3), 294-312. <https://doi.org/10.1080/01443410.2018.1543856>
- Hair, J. F., Black, W. C., Babin, B. J., & Anderson, R. E. (2014). Multivariate data analysis (new int. ed.). *Har-*

low: Pearson Education. <https://www.worldcat.org/title/multivariate-data-analysis/oclc/900353065>

Hanushek, E. A., Rivkin, S. G., & Schiman, J. C. (2016). Dynamic effects of teacher turnover on the quality of instruction. *Economics of Education Review*, 55, 132-148. <https://doi.org/10.1016/j.econedurev.2016.08.004>

Harlow, L. L., Mulaik, S. A., & Steiger, J. H. (Eds.). (2016). *What If There Were No Significance tests?: Classic Edition*. <https://doi.org/10.4324/9781315629049>

Hernando-Malipot, M. (2018, June 16). Teacher migration from private to public schools is a problem. *Manila Bulletin*. <https://mb.com.ph/2018/06/16/teacher-migration-from-private-to-public-schools-is-a-problem/>

Idris, F., Hassan, Z., Ya'acob, A., Gill, S. K., & Awal, N. A. M. (2012). The role of education in shaping youths' national identity. *Procedia-Social and Behavioral Sciences*, 59, 443-450. <https://doi.org/10.1016/j.sbspro.2012.09.299>

Imran, R., Allil, K., & Mahmoud, A. B. (2017). Teacher's turnover intentions: Examining the impact of motivation and organizational commitment. *International Journal of Educational Management*, 31(6), 828-842. <https://doi.org/10.1108/IJEM-05-2016-0131>

Jonathan, H., Darroux, C., & Thibeli, M. (2013). Exploring the effect of job satisfaction and demographic factors on affective, normative and continuance commitment: an empirical evidence of public secondary school teachers in Tanzania. *Journal of Education and Practice*, 4(23), 85-96. <https://core.ac.uk/download/pdf/234634836.pdf>

Jonathan, H., Thibeli, M., & Darroux, C. (2013). Impact investigation of organizational commitment on inten-

tion to leave of public secondary school teachers in Tanzania. *Developing Country Studies*, 3(11), 78-91. <https://core.ac.uk/download/pdf/234681336.pdf>

- Khairunnisa, L., Mariatin, E., & Zahreni, S. (2021). The Influence of organizational culture on turnover intention of x hospital employees. *International Journal of Progressive Sciences and Technologies*, 27(2), 733-741. <http://ijpsat.es/index.php/ijpsat/article/view/3319>
- Khan, S. (2015). Organizational commitment among public and private school teachers. *The International Journal of Indian Psychology*, 2(3), 65-73. <https://doi.org/10.25215/0203.081>
- Klein, H. J., & Park, H. M. (2015). Organizational commitment. In *International Encyclopedia of the Social & Behavioral Sciences: Second Edition*. Elsevier Inc. 334-340. <https://doi.org/10.1016/B978-0-08-097086-8.22032-1>
- Liu, S., & Onwuegbuzie, A. J. (2012). Chinese teachers' work stress and their turnover intention. *International Journal of Educational Research*, 53, 160-170. <https://doi.org/10.1016/j.ijer.2012.03.006>
- Mashile, D. A., Munyeka, W., & Ndlovu, W. (2019). Organizational culture and turnover intentions among academics: a case of a rural-based university. *Studies in Higher Education*, 1-9. <https://doi.org/10.1080/03075079.2019.1637844>
- Maqsood, A., Hanif, R., Rehman, G., & Glenn, W. (2012). Validation of the three-component model of organizational commitment questionnaire. *FWU Journal of Social Sciences*, 6(2). <https://www.proquest.com/docview/1353538093?pq-origsite=gscholar&fromopenview=true>

McInerney, D. M., Ganotice Jr, F. A., King, R. B., Marsh, H. W., & Morin, A. J. (2015). Exploring commitment and turnover intentions among teachers: What we can learn from Hong Kong teachers. *Teaching and Teacher Education, 52*, 11-23. <https://doi.org/10.1016/j.tate.2015.08.004>

Montemayor, M. (2018, March 19). *Class-size affects students' learning: DepEd*. Philippine News Agency [PNA].<https://www.pna.gov.ph/articles/1029281>

Obal, M. W., Krey, N., & Bushardt, C. (Eds.). (2015). *Let's get engaged! Crossing the threshold of marketing's engagement era: Proceedings of the 2014 Academy of Marketing Science (AMS) Annual Conference*. Springer. [https://books.google.com.ph/books?hl=en&lr=&id=WMI-vCwAAQBAJ&oi=fnd&pg=PR5&dq=Obal,+M.+W.,+Krey,+N.,+%26+Bushardt,+C.+\(Eds.\).+\(2015\).+Let%27s+get+engaged!+Crossing+the+threshold+of+marketing%E2%80%99s+engagement+era:+Proceedings+of+the+2014+Academy+of+Marketing+Science+\(AMS\)+Annual+Conference.+Springer.+&ots=REaS2kmBxb&sig=fgIedlvYt1ynSEd--Q1hdg6Mtik&redir_esc=y#v=onepage&q=Obal%2C%20M.%20W.%2C%20Krey%2C%20N.%2C%20%26%20Bushardt%2C%20C.%20\(Eds.\).%20\(2015\).%20Let%27s%20get%20engaged!%20Crossing%20the%20threshold%20of%20marketing%E2%80%99s%20engagement%20era%3A%20Proceedings%20of%20the%202014%20Academy%20of%20Marketing%20Science%20\(AMS\)%20Annual%20Conference.%20Springer.&f=false](https://books.google.com.ph/books?hl=en&lr=&id=WMI-vCwAAQBAJ&oi=fnd&pg=PR5&dq=Obal,+M.+W.,+Krey,+N.,+%26+Bushardt,+C.+(Eds.).+(2015).+Let%27s+get+engaged!+Crossing+the+threshold+of+marketing%E2%80%99s+engagement+era:+Proceedings+of+the+2014+Academy+of+Marketing+Science+(AMS)+Annual+Conference.+Springer.+&ots=REaS2kmBxb&sig=fgIedlvYt1ynSEd--Q1hdg6Mtik&redir_esc=y#v=onepage&q=Obal%2C%20M.%20W.%2C%20Krey%2C%20N.%2C%20%26%20Bushardt%2C%20C.%20(Eds.).%20(2015).%20Let%27s%20get%20engaged!%20Crossing%20the%20threshold%20of%20marketing%E2%80%99s%20engagement%20era%3A%20Proceedings%20of%20the%202014%20Academy%20of%20Marketing%20Science%20(AMS)%20Annual%20Conference.%20Springer.&f=false)

Philippine Statistics Authority. (2019). *Education quality in the Philippines*. https://unstats.un.org/sdgs/files/meetings/sdg-inter-workshop-jan-2019/Session%2011.b.3_Philippines__Education%20Equality%20AssessmentFINAL4.pdf

- Philippine Statistics Authority. (2020). *Employment situation in January 2020*. <https://psa.gov.ph/statistics/survey/labor-and-employment/labor-force-survey/title/Employment%20Situation%20in%20January%202020>
- Quismorio, E. (2019, December 04). Private school teachers deserve pay hike too, says solon. *Manila Bulletin*. <https://mb.com.ph/2019/12/04/private-school-teachers-deserve-pay-hike-too-says-solon/>
- Roodt, G. (2004). Turnover intentions. *Unpublished document. Johannesburg: University of Johannesburg*.
- Selamat, N., Nordin, N., & Adnan, A. A. (2013). Rekindle teacher's organizational commitment: The effect of transformational leadership behavior. *Procedia-Social and Behavioral Sciences*, 90, 566-574. <https://doi.org/10.1016/j.sbspro.2013.07.127>
- Shah, N. H., & Jumani, N. B. (2015). Relationship of job satisfaction and turnover intention of private secondary school teachers. *Mediterranean Journal of Social Sciences*, 6(4), 313. <https://doi.org/10.5901/mjss.2015.v6n4s2p313>
- Sow, M. T. (2015). *Relationship between organizational commitment and turnover intentions among healthcare internal auditors* (Doctoral dissertation, Walden University). <https://scholarworks.waldenu.edu/cgi/viewcontent.cgi?article=2351&context=dissertations>
- Sutcher, L., Darling-Hammond, L., & Carver-Thomas, D. (2016). A coming crisis in teaching? Teacher supply, demand, and shortages in the U.S. *Learning Policy Institute*. <https://eric.ed.gov/?id=ED606665>
- Sutcher, L., Darling-Hammond, L., & Carver-Thomas, D. (2019). Understanding teacher shortages: An analysis of teacher supply and demand in the United

- States. *Education Policy Analysis Archives*, 27, 35. <https://doi.org/10.14507/epaa.27.3696>
- Tett, R. P., & Meyer, J. P. (1993). Job satisfaction, organizational commitment, turnover intention, and turnover: path analyses based on meta-analytic findings. *Personnel Psychology*, 46(2), 259-293. <https://doi.org/10.1111/j.1744-6570.1993.tb00874.x>
- Turney, G. (2021). *Leadership Role in Decreasing Nurse Turnover* (Doctoral dissertation, Gardner-Webb University). <https://www.proquest.com/dissertations-theses/leadership-role-decreasing-nurse-turnover/docview/2572989577/se-2?accountid=50192>
- United Nations Educational, Scientific, and Cultural Organization (2016). The world needs almost 69 million new teachers to reach the 2030 education goals. *United Nations Educational, Scientific and Cultural Organization*. <https://unesdoc.unesco.org/ark:/48223/pf0000246124>
- Vaske, J. J., Beaman, J., & Sponarski, C. C. (2017). Rethinking internal consistency in Cronbach's Alpha. *Leisure Sciences*, 39(2), 163-173. <https://doi.org/10.1080/01490400.2015.1127189>
- Wiggan, G., Smith, D., & Watson-Vandiver, M. J. (2021). The national teacher shortage, urban education and the cognitive sociology of labor. *The Urban Review*, 53(1), 43-75. <https://doi.org/10.1007/s11256-020-00565-z>